

**Ergänzende Betriebsanleitung**  
***Additional operating manual***  
**PONGAMI (PFA U)**

# 1.1

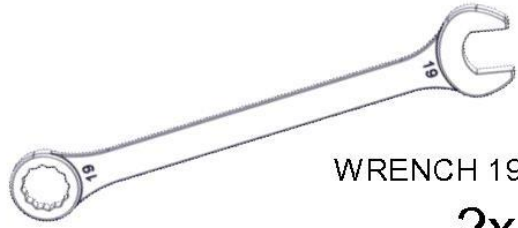
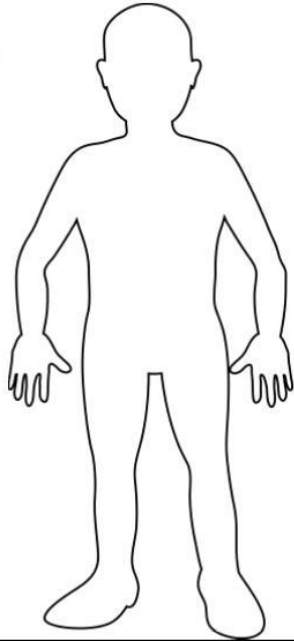

WRENCH 19

**2x**

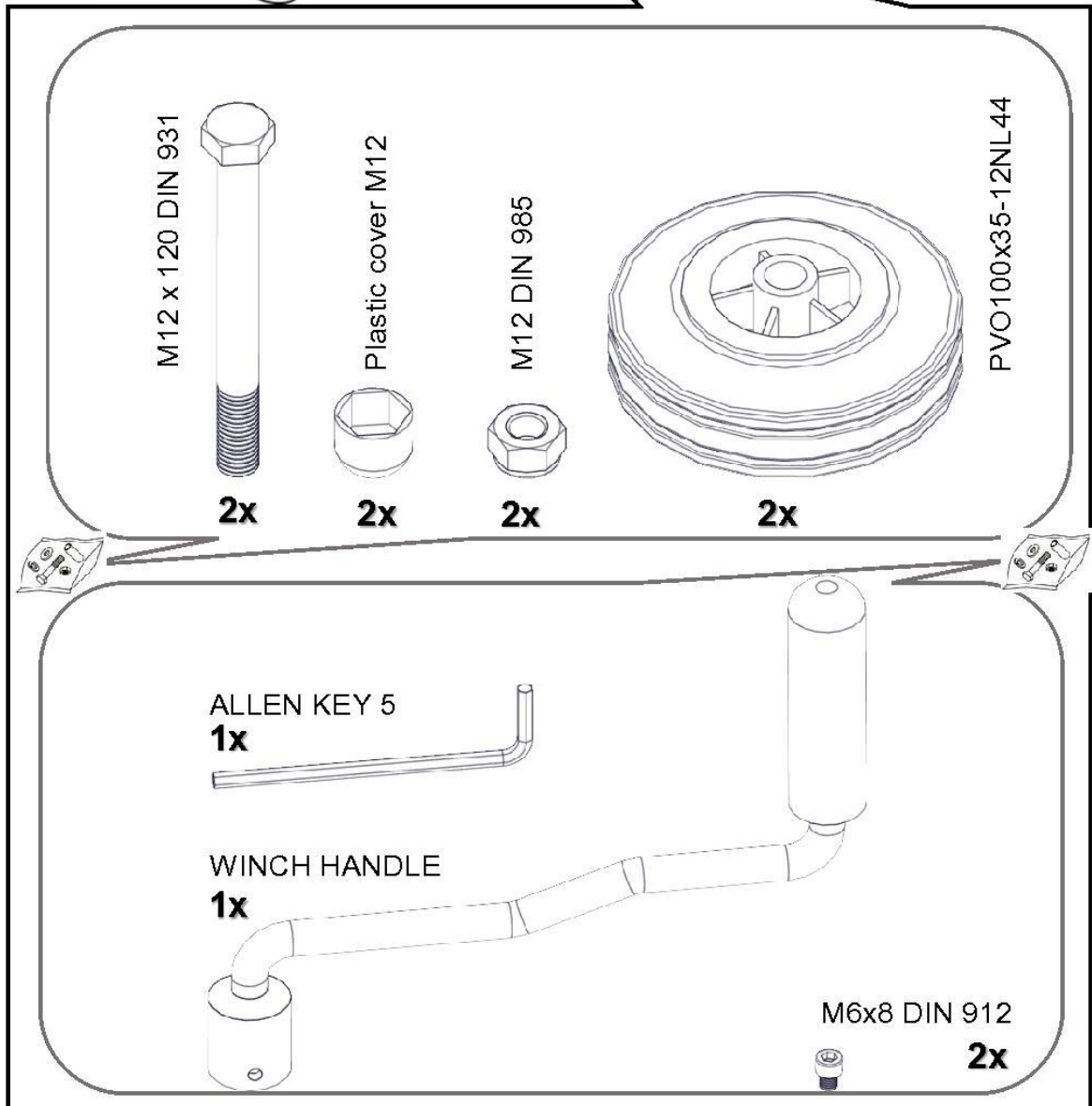
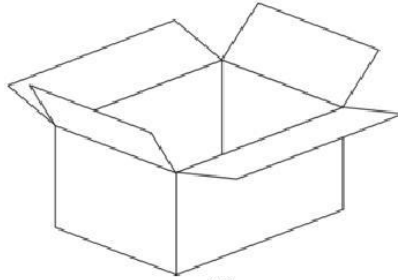

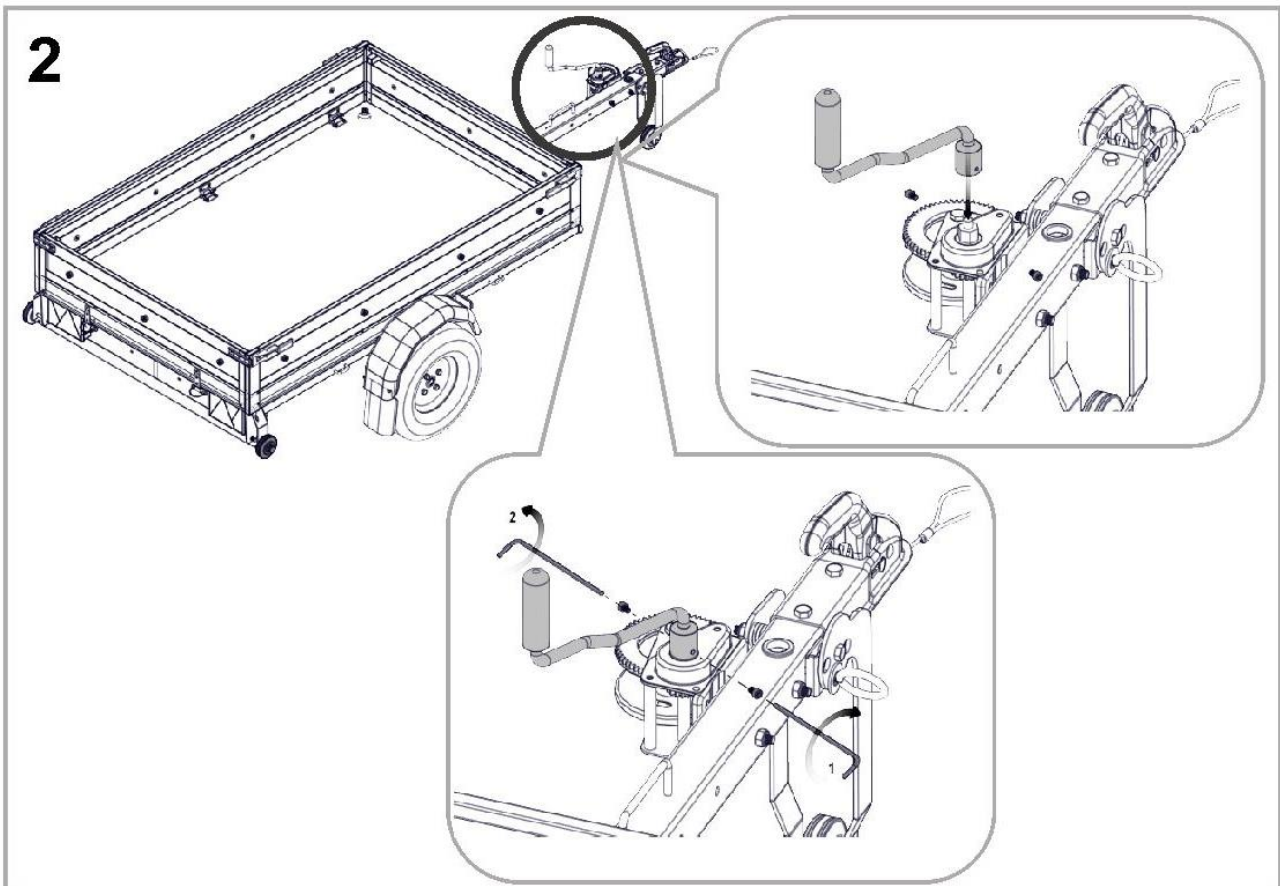
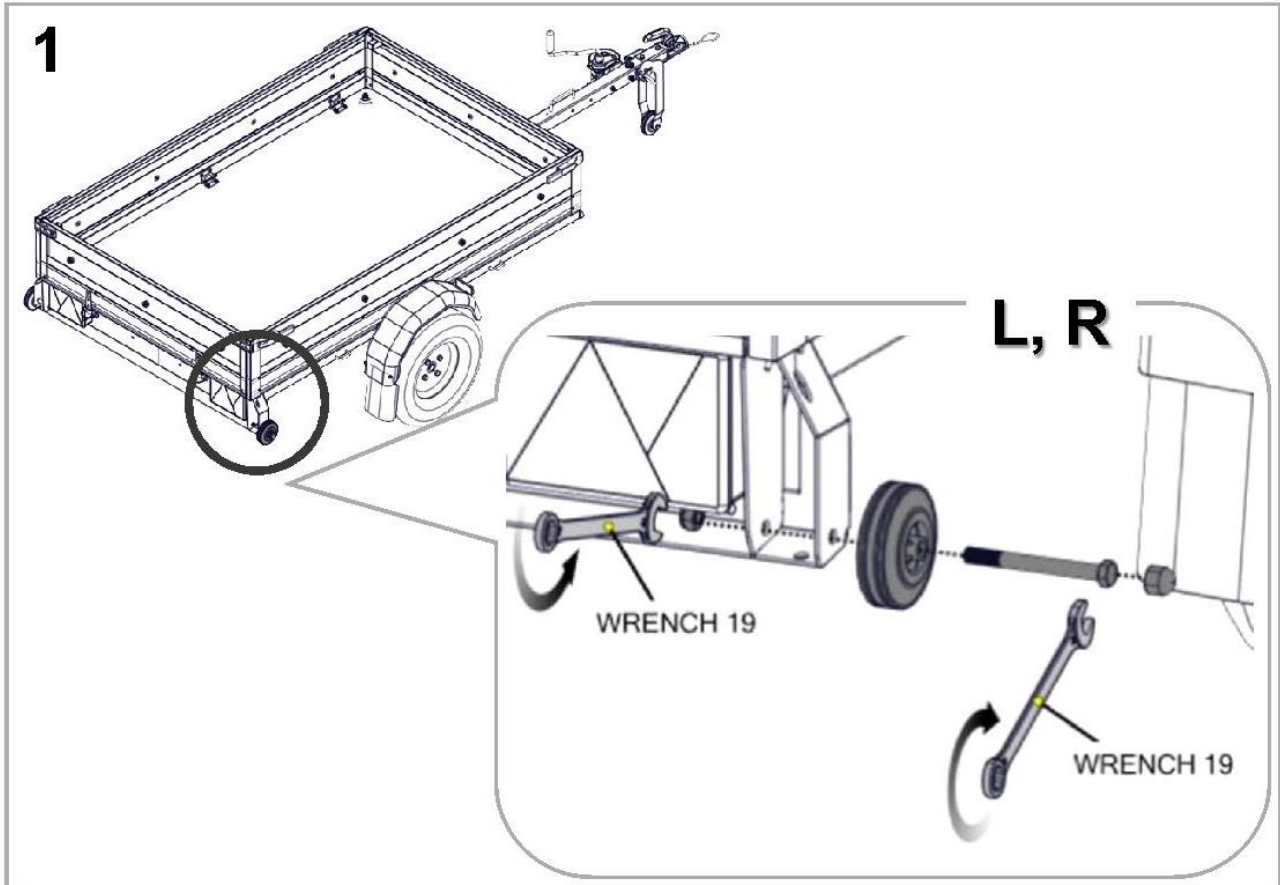

# 1.2

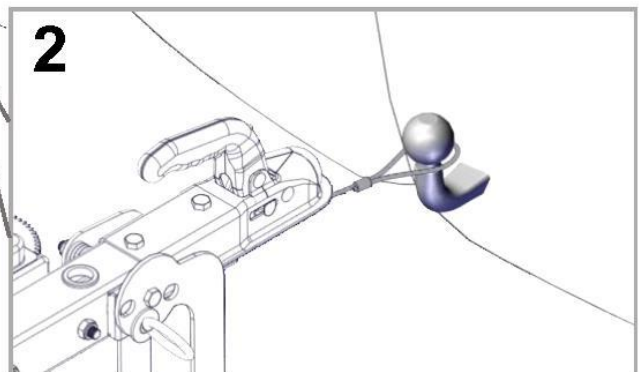
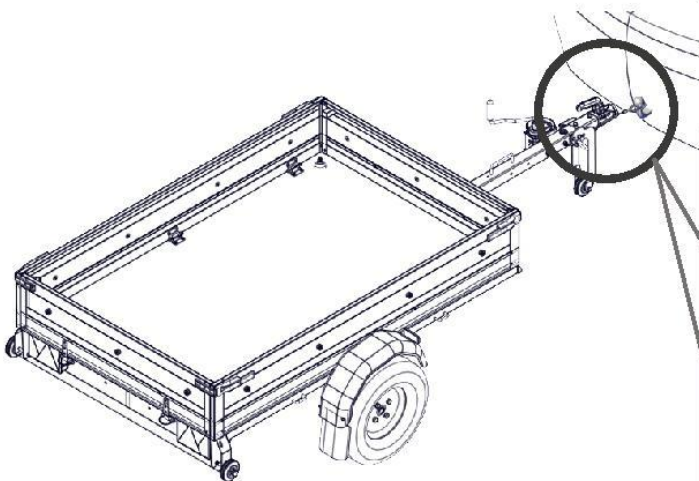
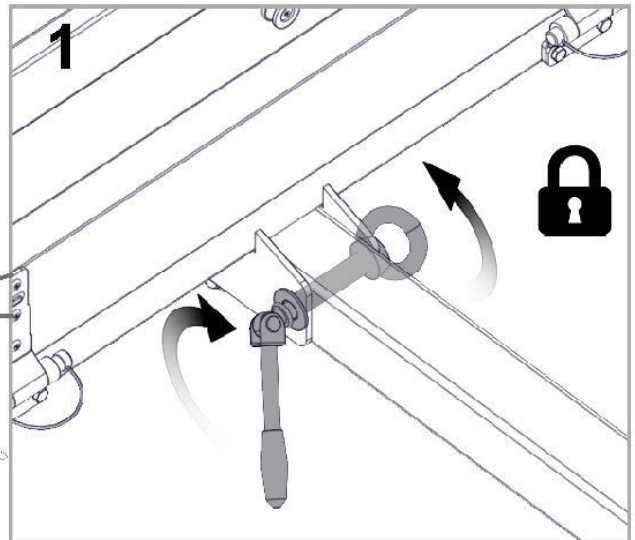
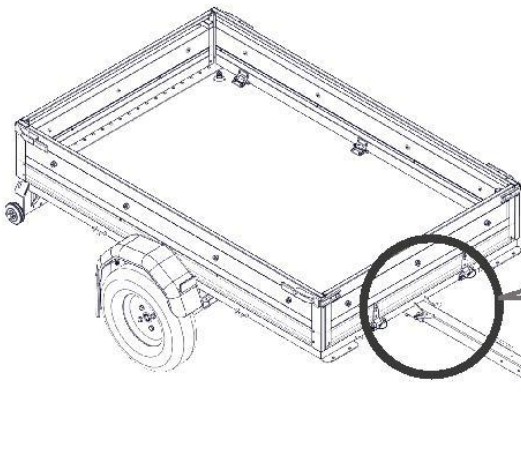
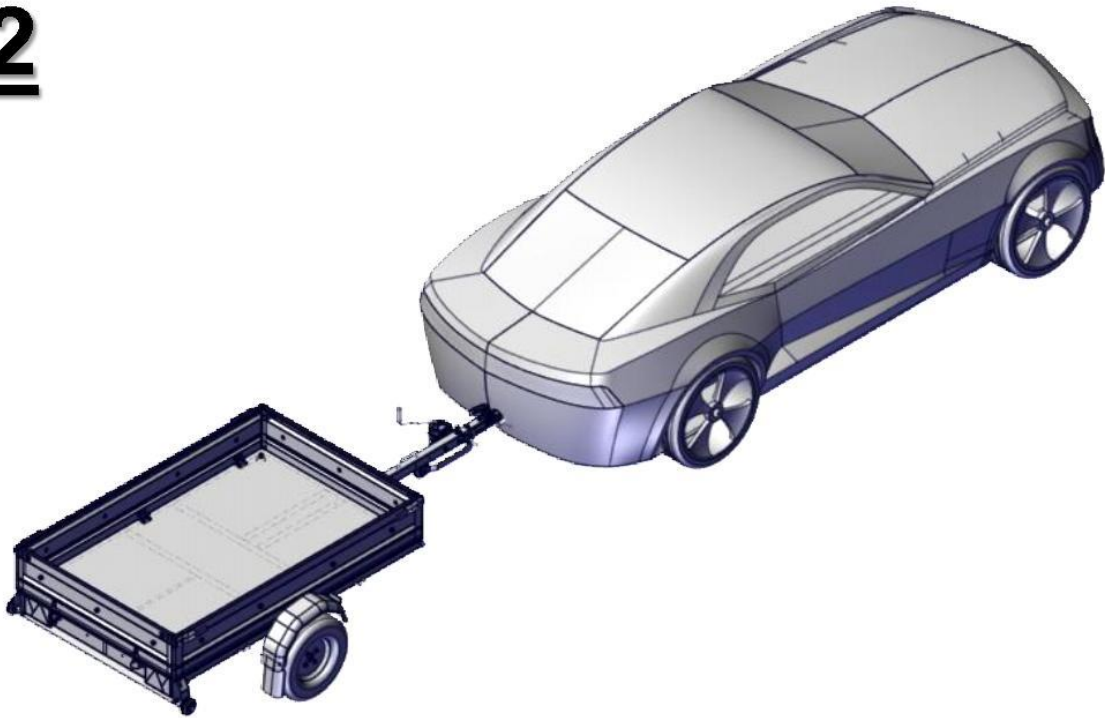

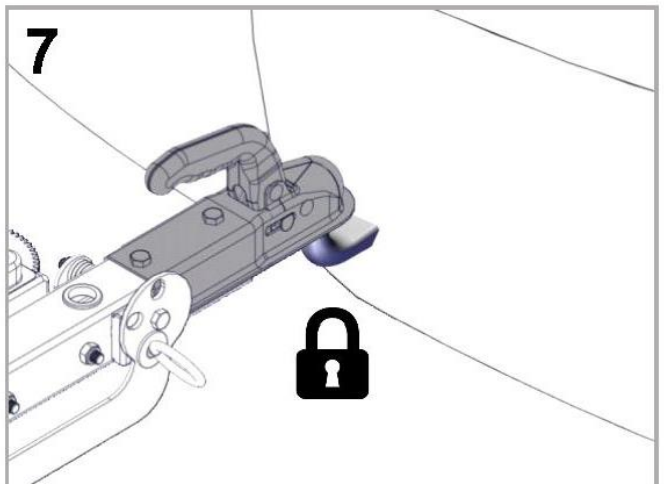
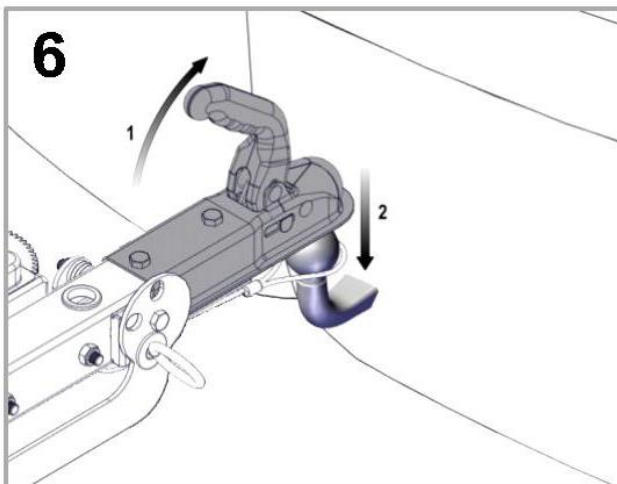
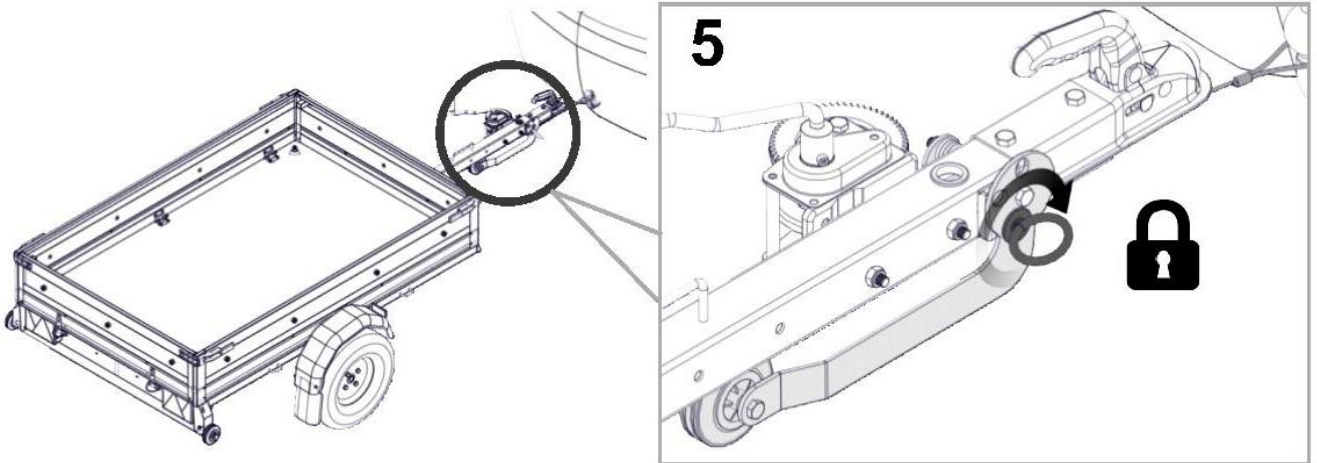
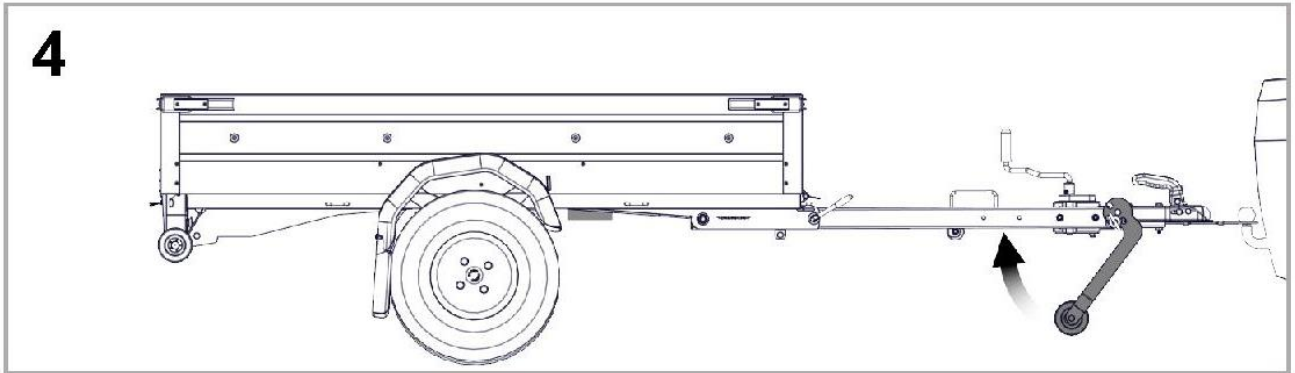
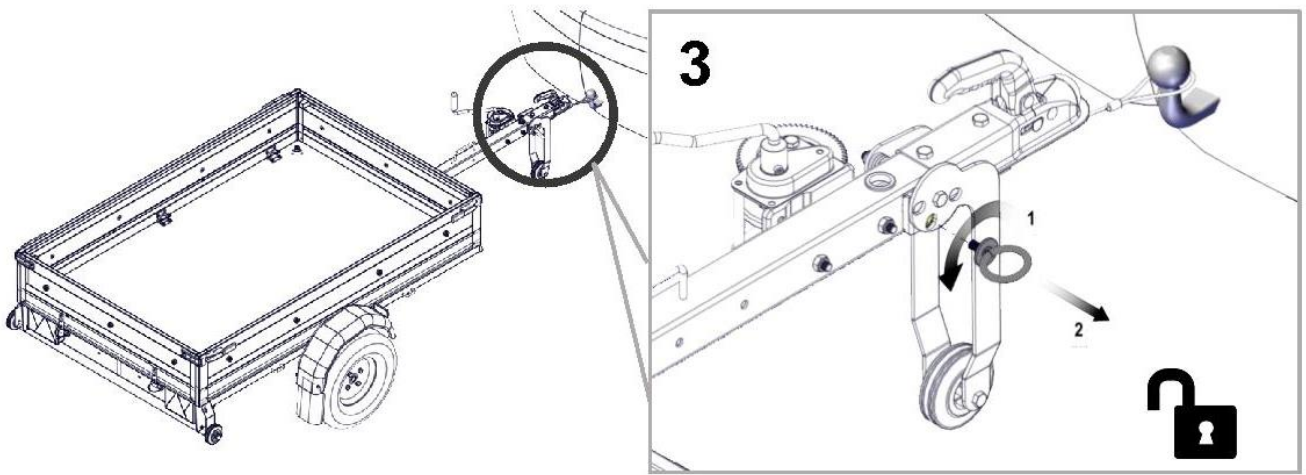

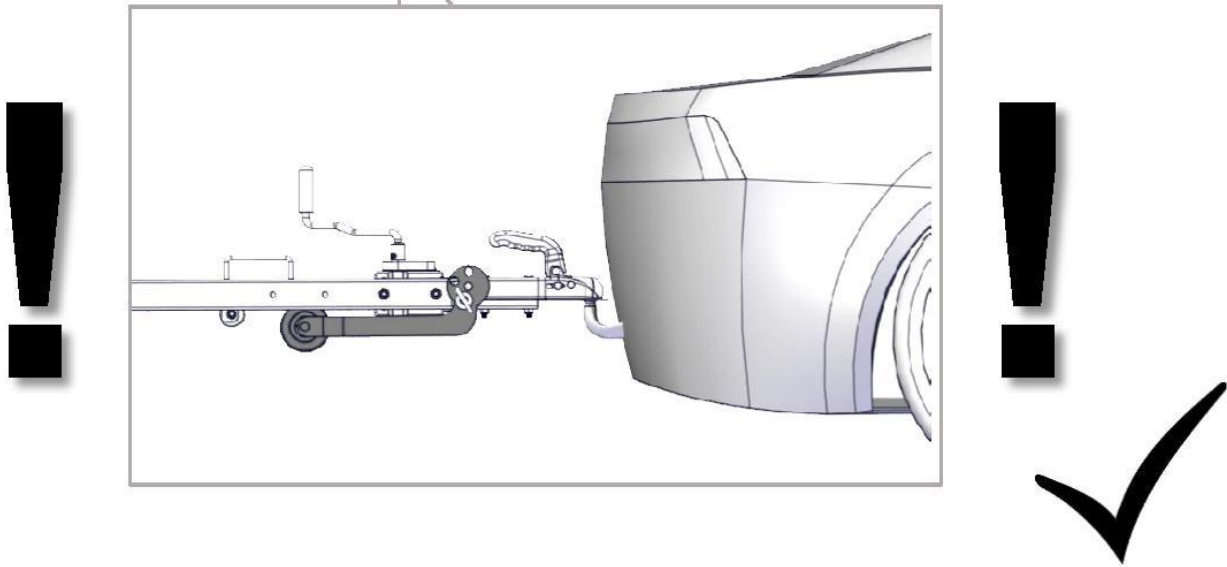
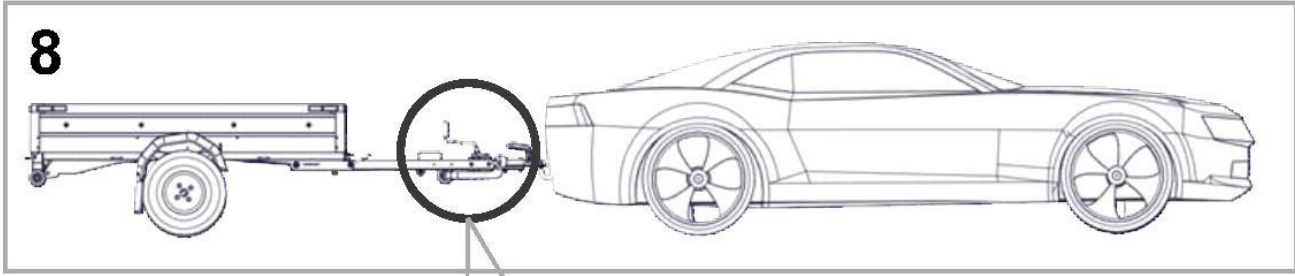

---

**1.3**

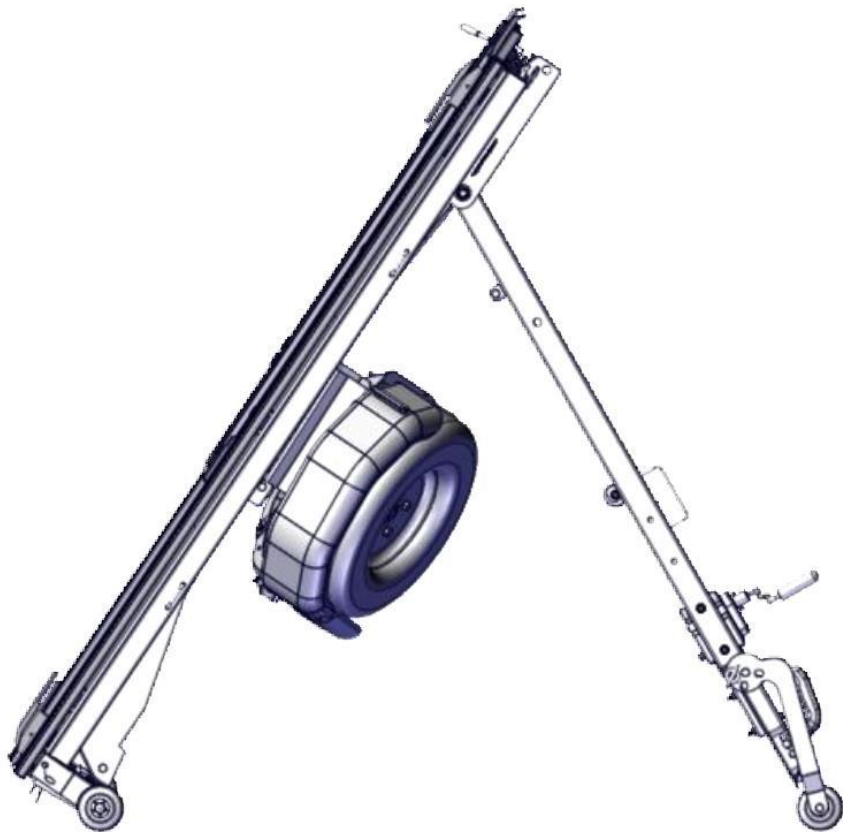

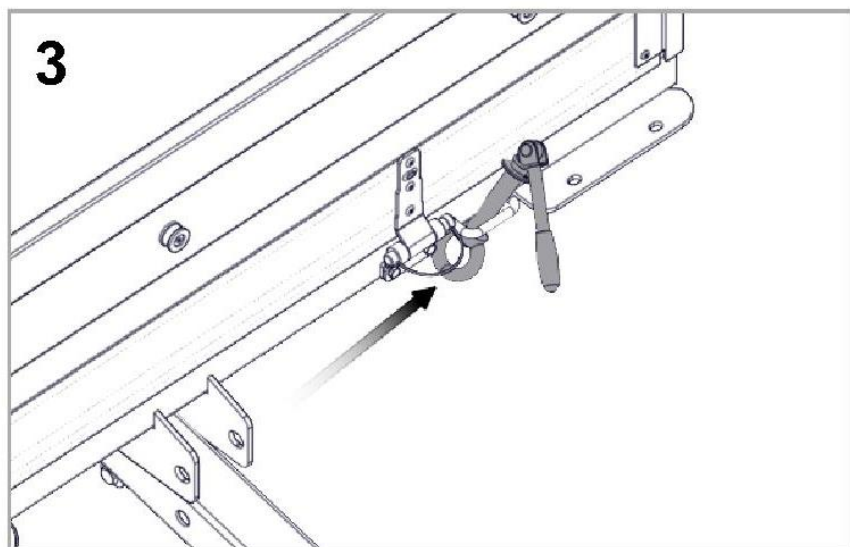
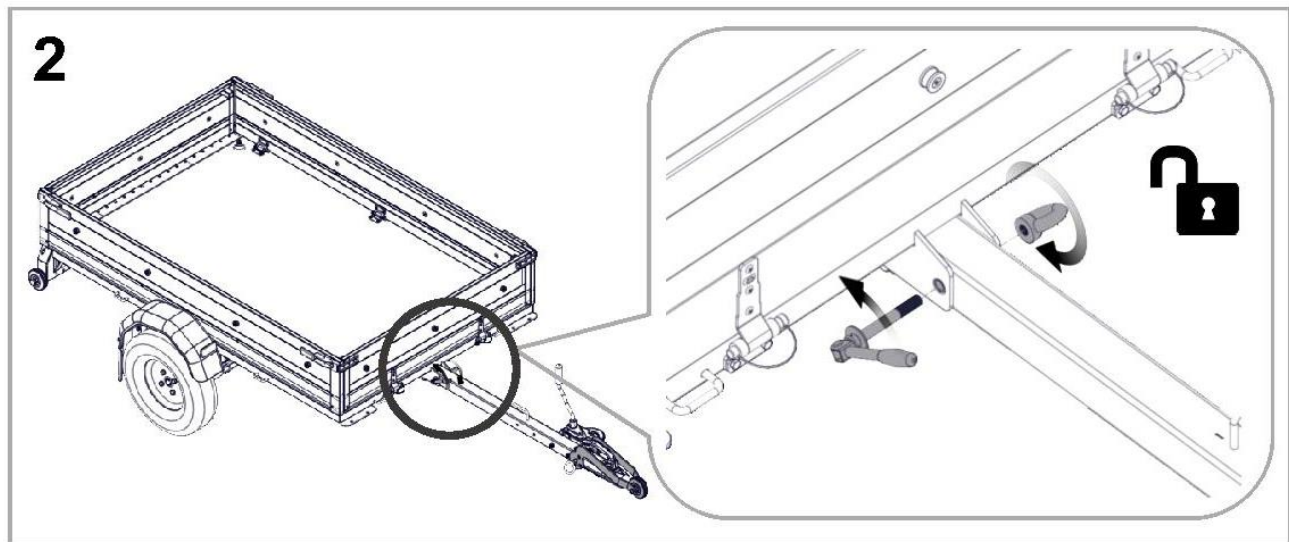
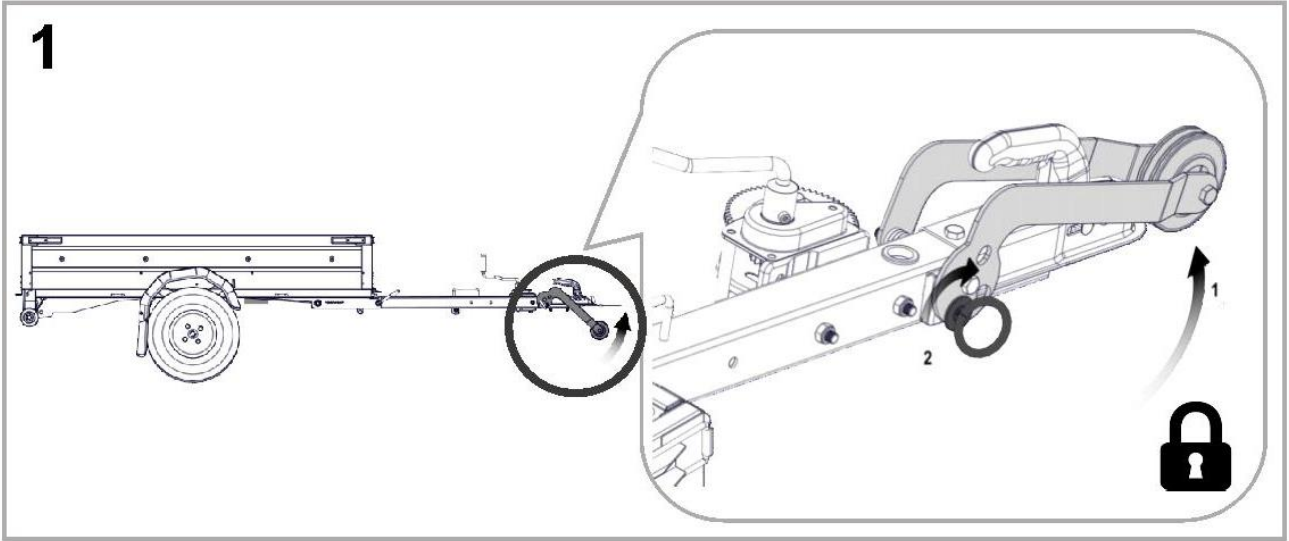

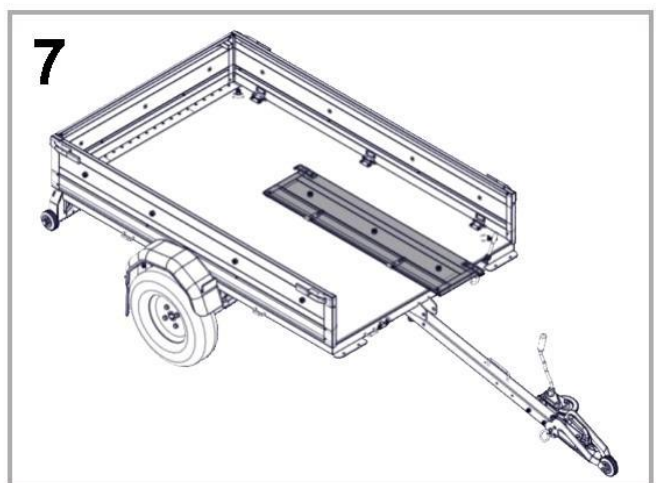
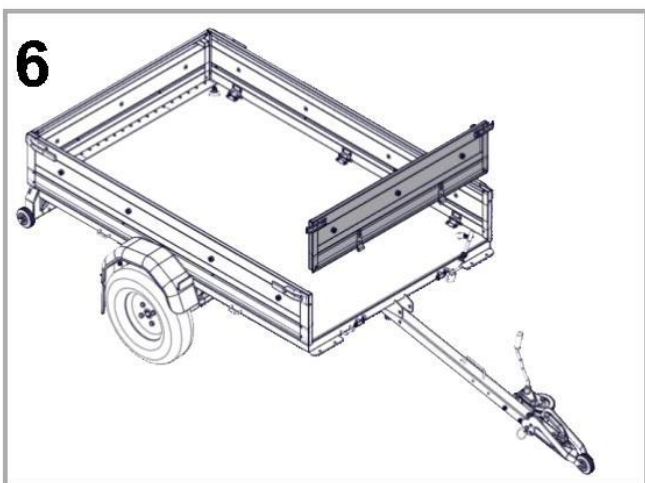
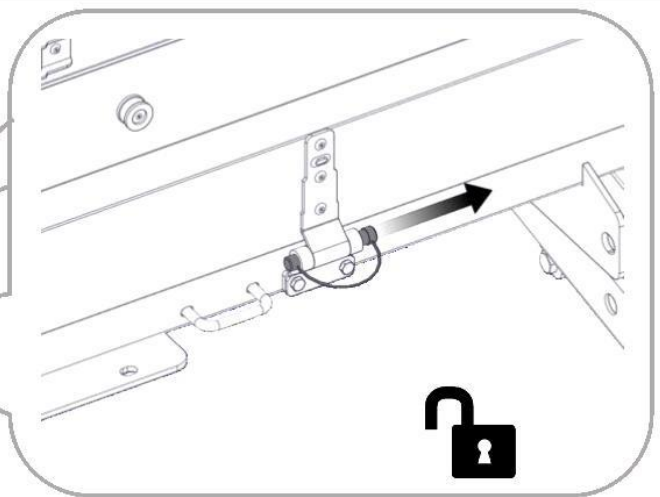
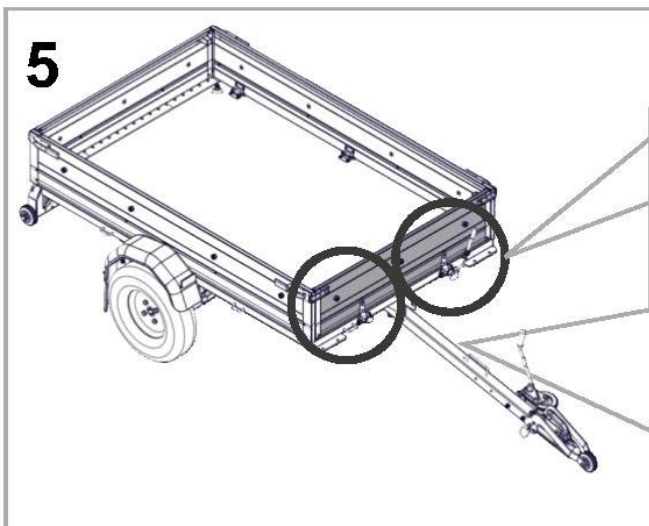
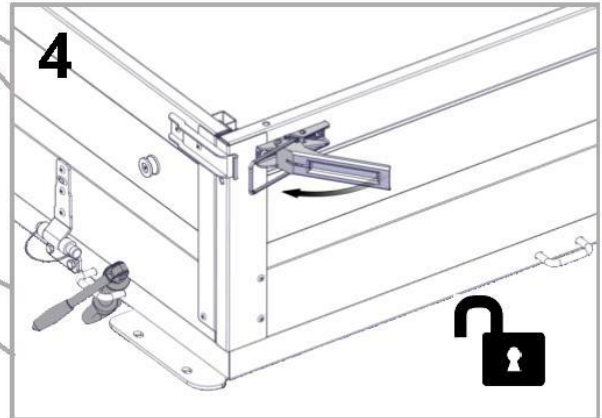
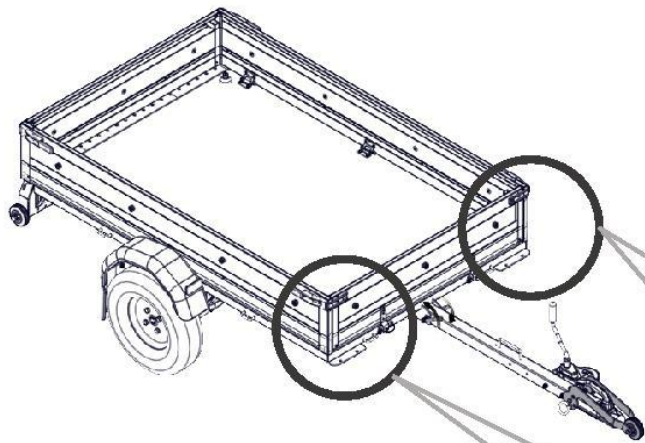

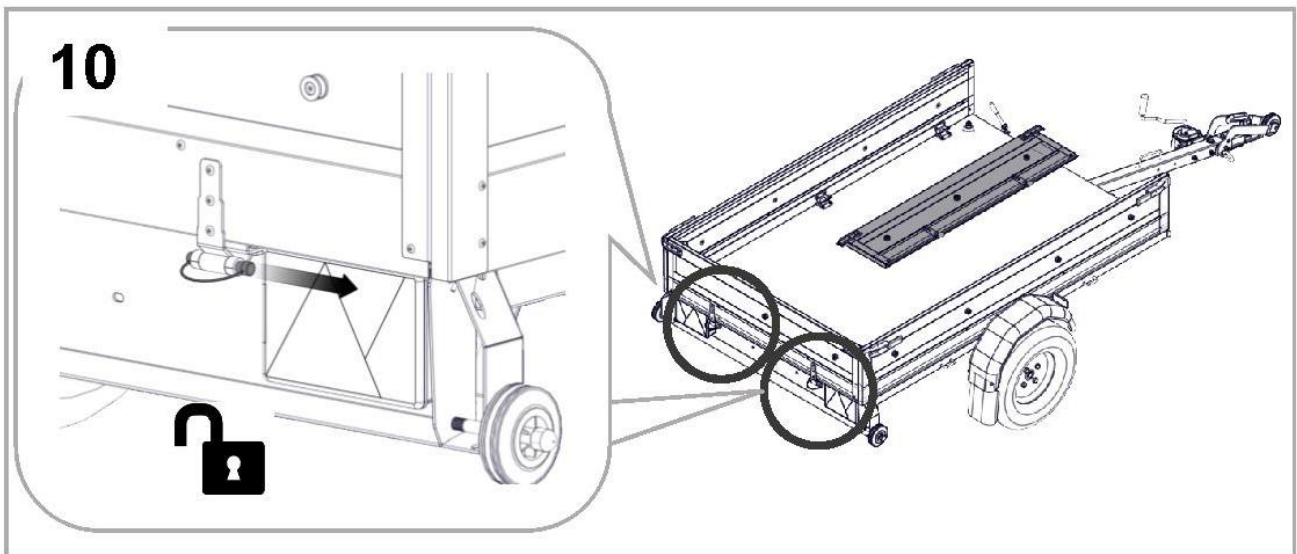
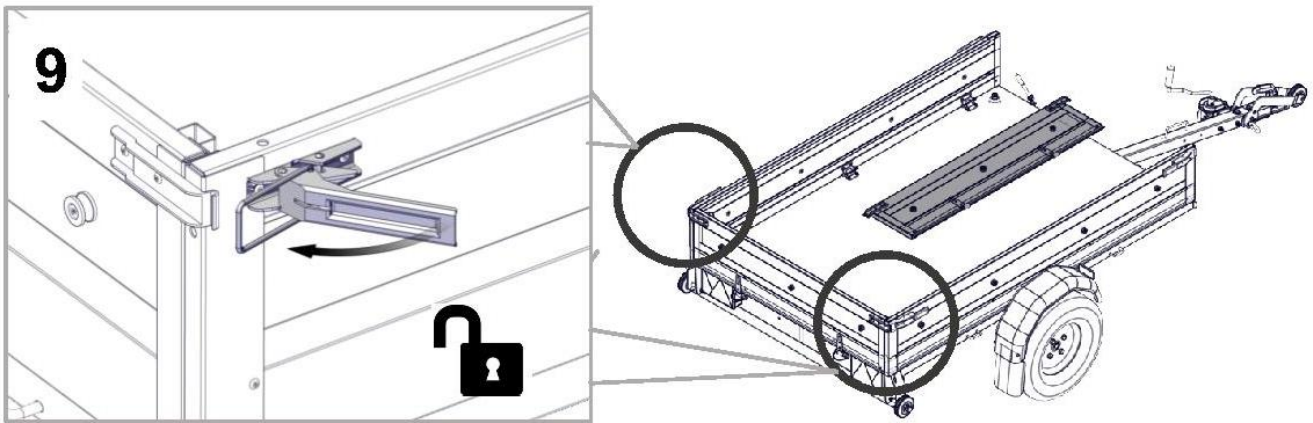
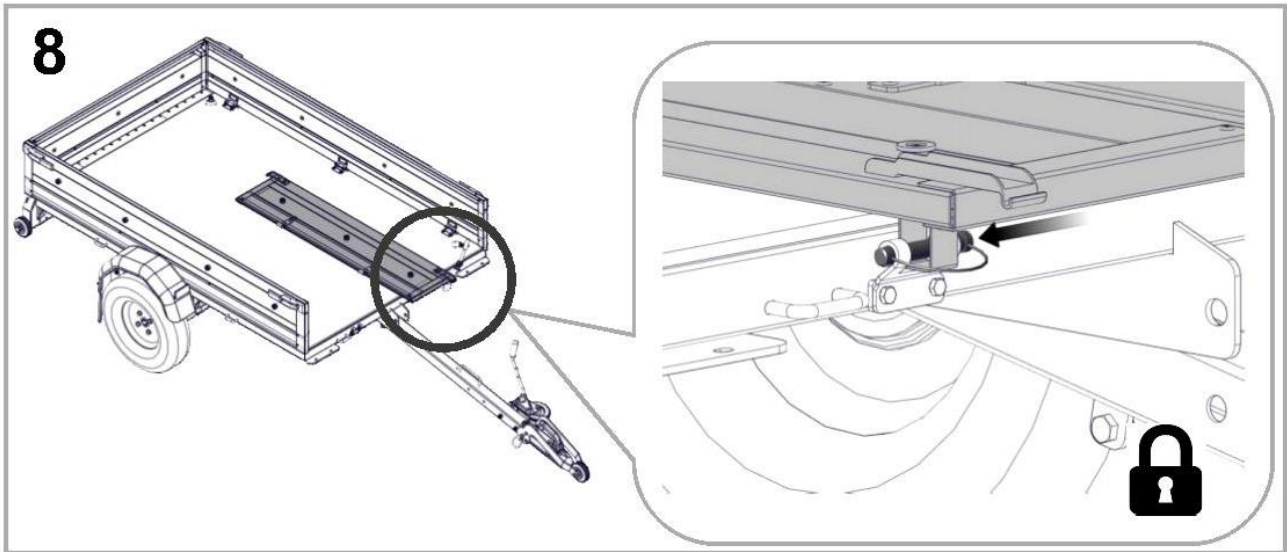

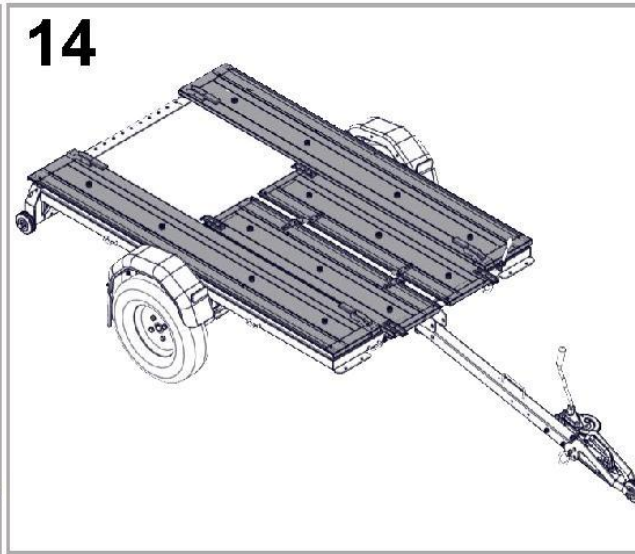
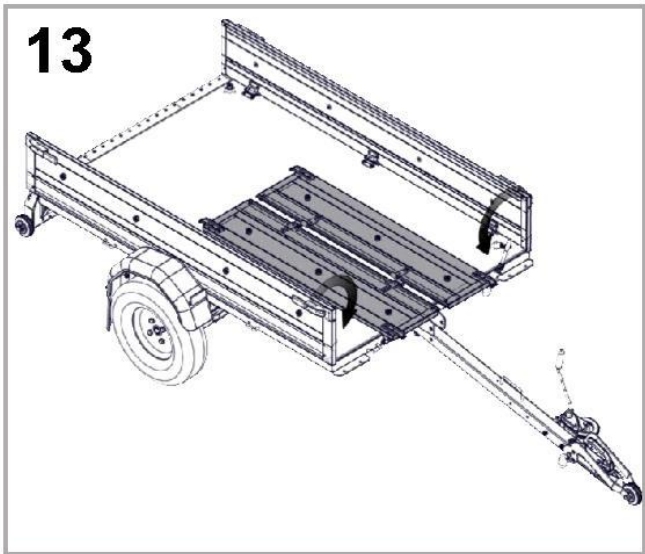
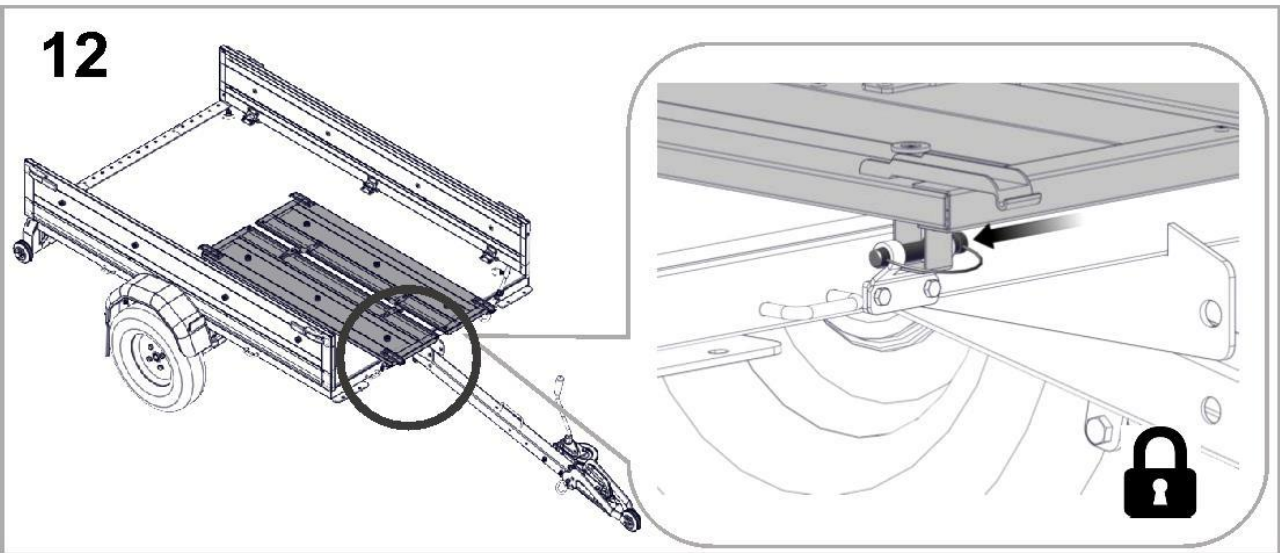
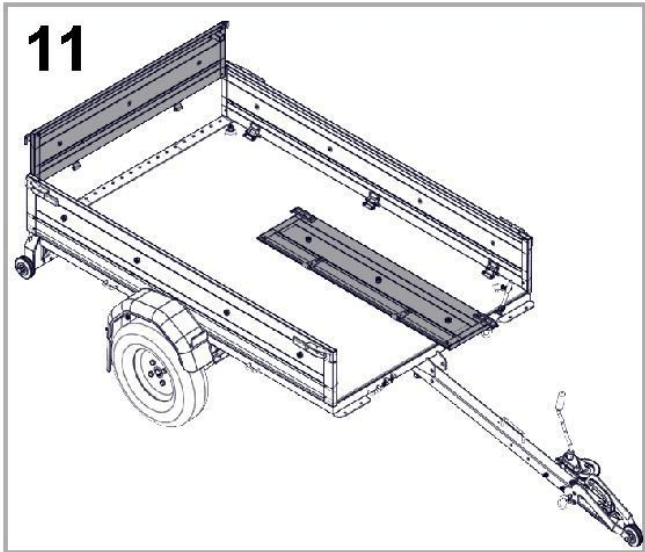

**15**

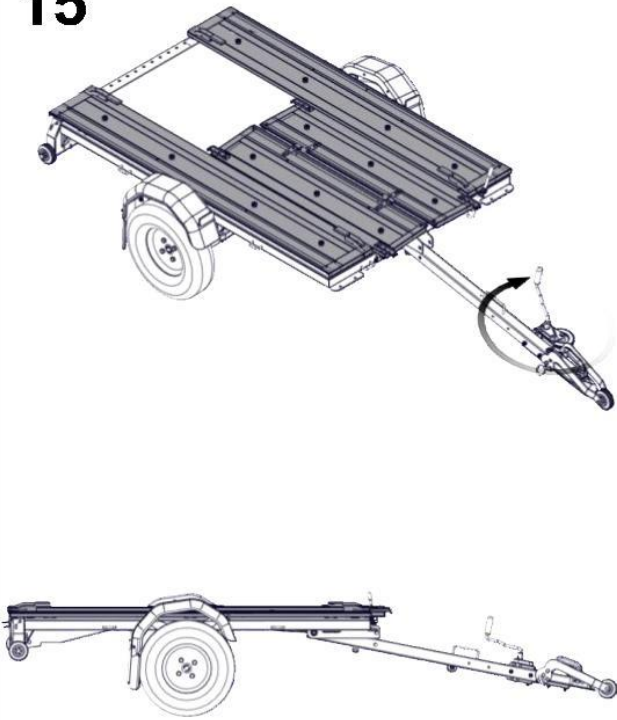

**16**

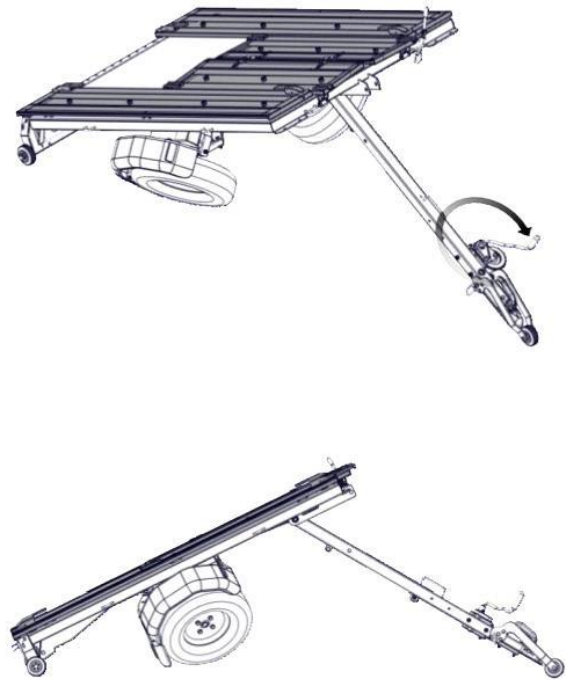

**17**

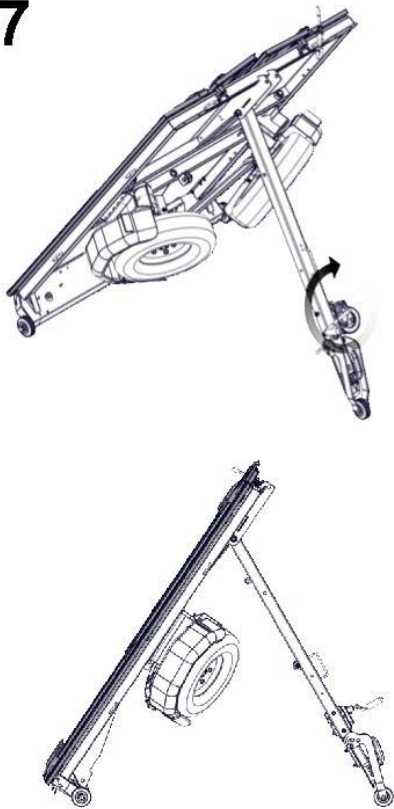

**18**

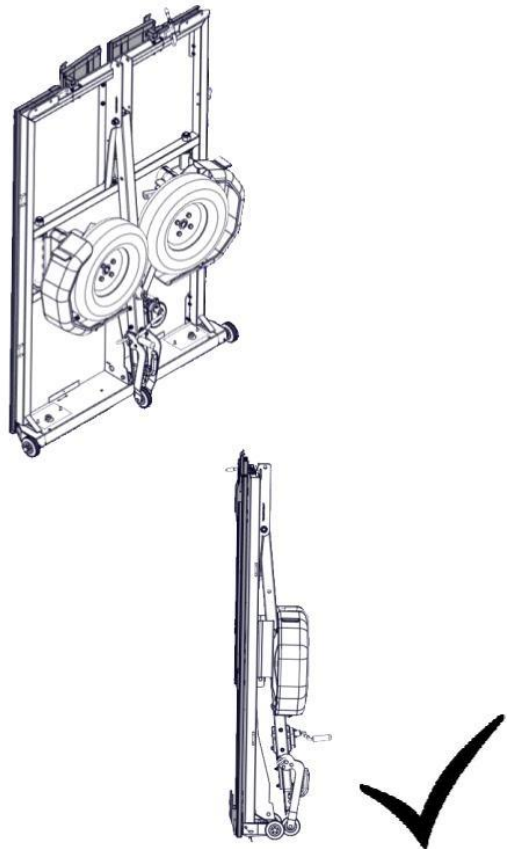

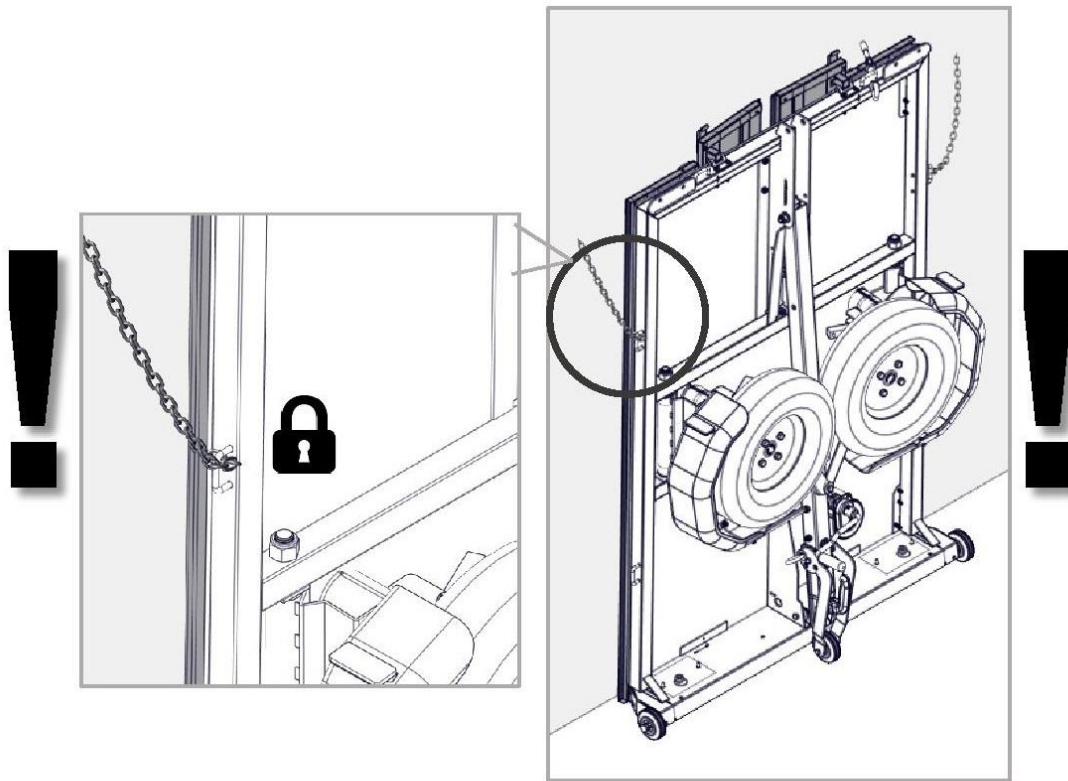

**ALL PICTURES SHOWN ARE FOR ILLUSTRATION PURPOSE ONLY. ACTUAL PRODUCT MAY VARY DUE TO PRODUCT ENHANCEMENT.**

1. Auflage 11/2018

**Pongratz**

**Pongratz Trailer-Group GmbH**

An der Bundesstraße 34, A-8772 Traboch  
Tel. +43 3843/26033-0, Fax DW 40  
office@pongraztrailers.com  
www.pongraztrailers.com